

# Signal System for Modular Layouts

## Occupancy Bus Utility Boards

Scale Nature Company offers Occupancy Bus Utility Boards to simplify adding the Signal System for Modular Layouts to your modules. These boards are not required to make the system work - they are completely optional. Two different kits are available:

### Occupancy Bus Cross-over Board (OBXB): for use in cross-over modules without trackside signals

- + built-in cross-over wiring pattern - allows module to use stock straight-through (patch) RJ45 cables to potentially eliminate cross-over cables inside the module.
- + built-in RJ45 jacks - eliminates cutting RJ45 cables and stripping/connecting their fine-gauge wires
- + wire-clamp terminals for connecting multiple detector and turnout-position status lines - eliminates separate terminal strips and crimp-on lugs
- + isolation diodes - ensures isolation of the Occupancy Bus wires

#### OBXB Application Examples

The Signal System for Modular Layouts requires cross-over modules to have an odd number of cross-overs in their internal Occupancy Bus. The examples below suggest some ways to meet this requirement.

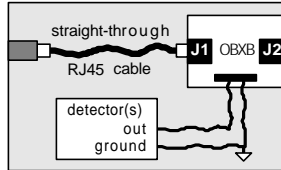

OBXB mounted in cross-over module near one end. J2 receives "jumper" cable from adjacent module. Straight-through RJ45 coupler used at the other module end.

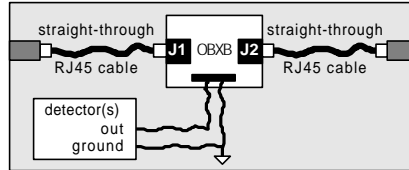

OBXB mounted in cross-over module near center. Two straight-through RJ45 cables form Occupancy Bus, for a total of one cross-over within module. Straight-through RJ45 couplers used at both module ends.

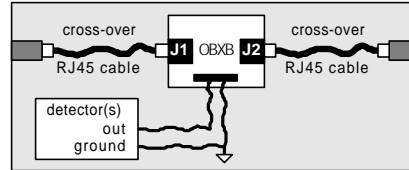

OBXB mounted in cross-over module near center. Two cross-over RJ45 cables form Occupancy Bus, for a total of three cross-overs within the module. Straight-through RJ45 couplers used at both module ends.

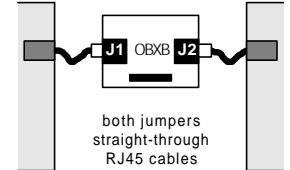

OBXB used with two straight-through RJ45 cables to jumper between modules (a cross-over is always required between modules).

### Occupancy Bus Cascade Board (OBCB): for use in cascade modules

- + built-in cascade wiring pattern - allows module to use stock straight-through (patch) RJ45 cables inside the module.
- + built-in RJ45 jacks - eliminates cutting RJ45 cables and stripping/connecting their fine-gauge wires
- + wire-clamp terminals for connecting current and optical detectors, turnout-position status indicators, and multiple signal controllers - eliminates separate terminal strips and crimp-on lugs
- + isolation diodes - ensures isolation of the Occupancy Bus wires

#### OBCB Application Examples

The Signal System for Modular Layouts uses cascade modules to define signal block boundaries, and requires them to have one optical detector and two current detectors. Cascade modules also often have trackside signals. The examples below suggest some ways to use the OBCB:

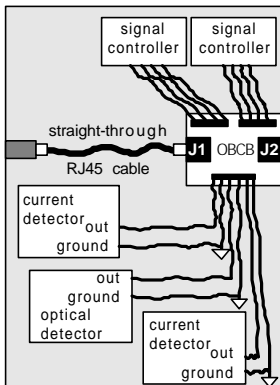

OBCB mounted in signal-equipped cascade module near one end. J2 receives "jumper" cable from adjacent module. Straight-through RJ45 coupler used at the other module end.

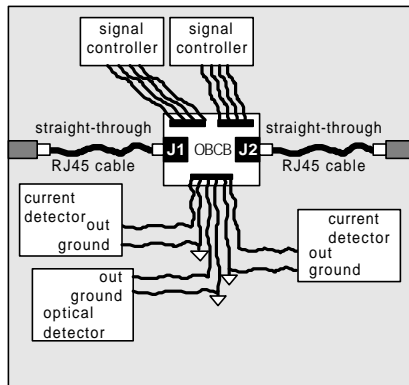

OBCB mounted in cascade module near center. Straight-through RJ45 couplers used at both module ends.

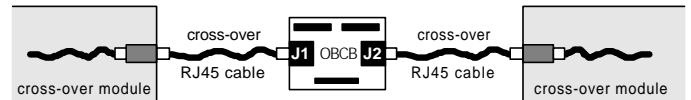

OBCB used as "portable" cascade between cross-over modules, for adding a signal block to a layout by splitting one long block into two shorter blocks.



#### OBCB Selectable Cascade Option

This option is available for the OBCB only - it adds a slide switch unit to select the board's wiring between cascade pattern or cross-over pattern. This is handy when two cascade modules are too close together in a setup, forming a very short signal block - this option allows converting one cascade module to a cross-over module which combines the short signal block into an adjacent long block.